

A CASE FOR CAPTURING AND ANALYZING TRENDS IN YOUR ALIGNMENT DATA

How to identify the root cause of a misalignment condition



A Case for Capturing and Analyzing Trends in Your Alignment Data

It is well known that misalignment is one of the greatest causes of failure in rotating equipment. In fact, research demonstrates that more than 50% of machine breakdowns are the direct result of poor alignment.

But correcting misalignment can be a challenge. Misalignment can have many causes. Alignment is not a static condition. Alignment changes. When a machine warms up, its alignment can shift with the thermal expansion of its parts.

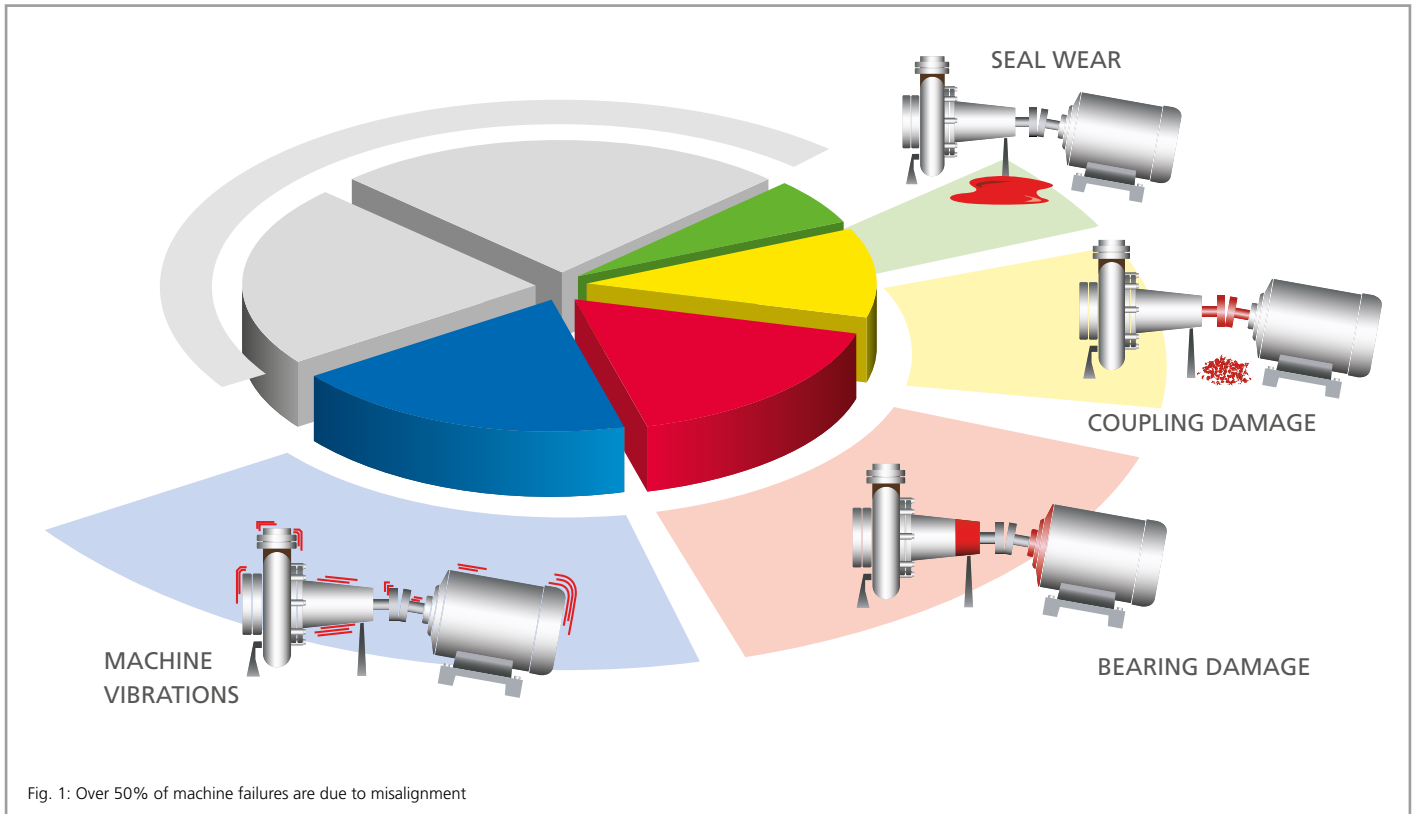

When a machine vibrates, its skids can move and affect its alignment. When minor process parameters such as pressure or temperature are modified, alignment can change. Even the simple and natural succession of the seasons can alter alignment and put machine assets at risk. Effectively countering the factors that

influence or alter alignment depends on understanding how the alignment of your machine changes over time and with use. It depends on accurate and careful analysis of the trends in your alignment data.

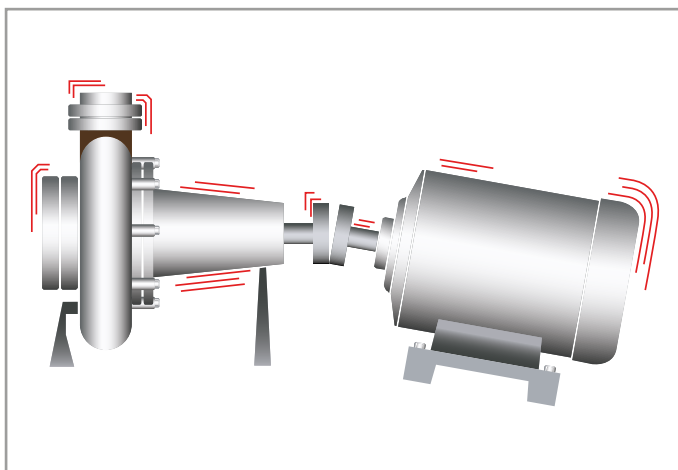

It Can Be Difficult to Identify the Cause of Misalignment

The root cause of a misalignment condition is not always obvious. Vibration analysis might uncover a misalignment problem, but it won't necessarily identify the reason for it.

Capturing alignment data before equipment is removed or disassembled, even when maintenance is undertaken for non-alignment reasons, may, over time, reveal hidden causes of misalignment. Periodically checking and recording alignment conditions generates useful information about correctable conditions that, if addressed, will reduce breakdowns, increase productivity, and save money.

Maybe it's a Foundation Problem

Capture and analysis of alignment data trends proved useful at a co-generation plant in the San Francisco area. In this real life example, a plant operator found that his machines needed realign-

ment every six months. The requirement was always the same, the turbine needed to be shimmed up another 4-6 mils.

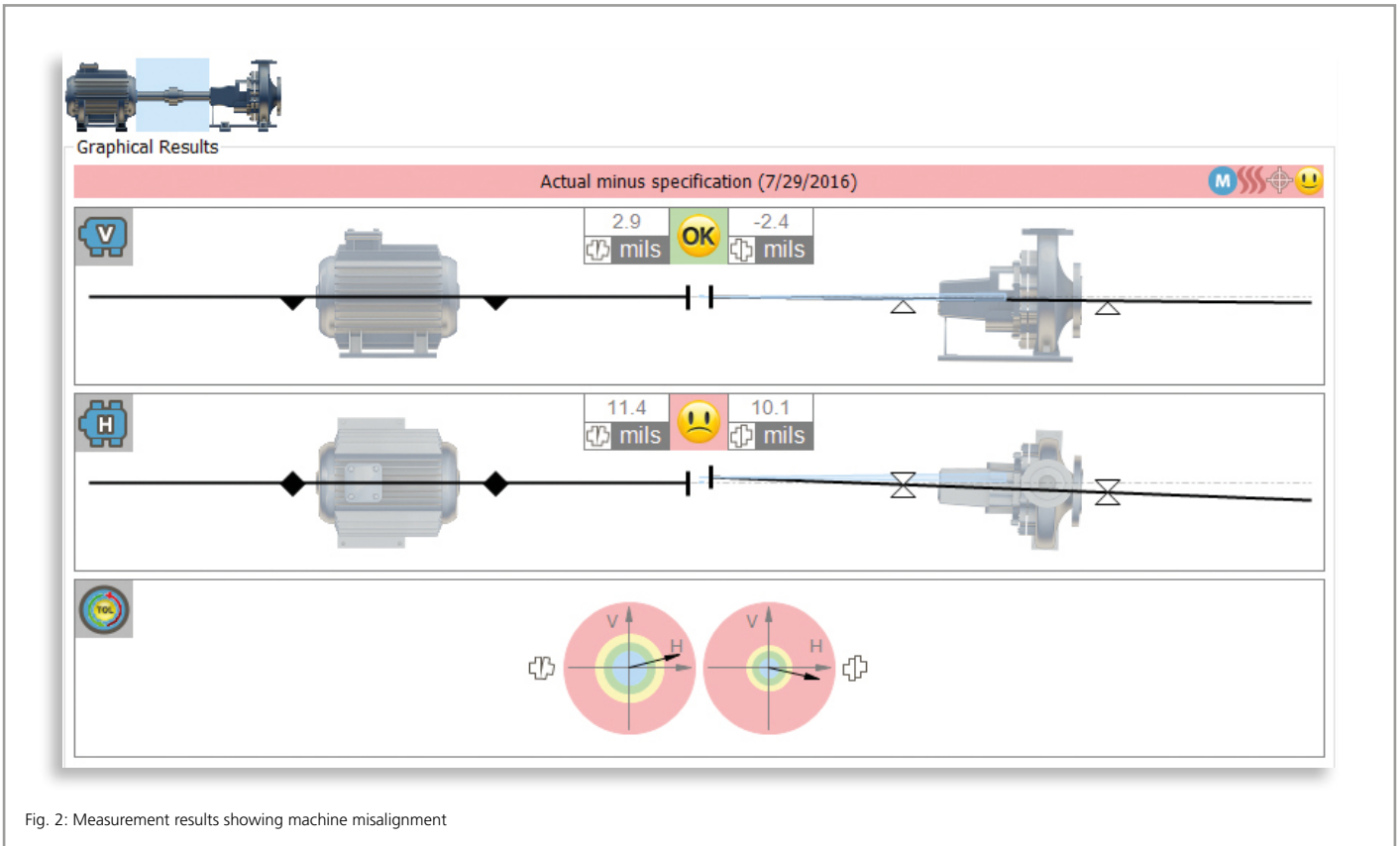

By analyzing the alignment trends over time, it was discovered that the turbine foundation, built on fill dirt in an area of land recovered from San Francisco Bay, was slowly sinking.

Vibration analysis had identified the misalignment problem, but only analysis of the gap and offset alignment trends revealed the reason why.

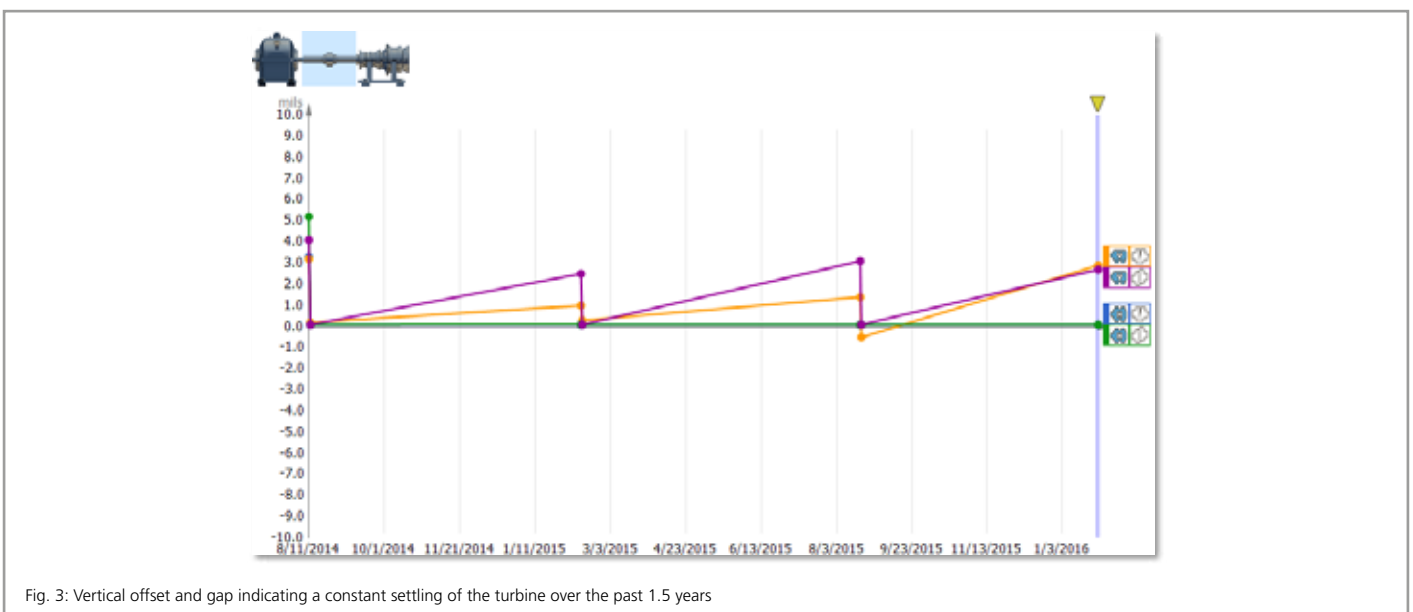

Maybe it's a Weather Problem

Capture and analysis of alignment trends also assisted in correcting pump alignment problems in a high desert environment. In this case, a pump and pipe assembly which had been properly installed and aligned was inexplicably running in and out of alignment. Again, vibration analysis exposed the misalignment, but it was analysis of alignment trends that identified the source of the problem. Trend charts revealed that seasonal tempera-

ture extremes were negatively affecting alignment. In the western American desert, summer heat often runs above 110° F (43° C), while in the winter temperatures sometimes fall below 0° F (-18° C). The reason for misalignment was easy to identify when examining the trends in the coupling clearances. As the outside temperatures changed with the seasons, a corresponding misalignment of the pump and pipe assembly became readily apparent.

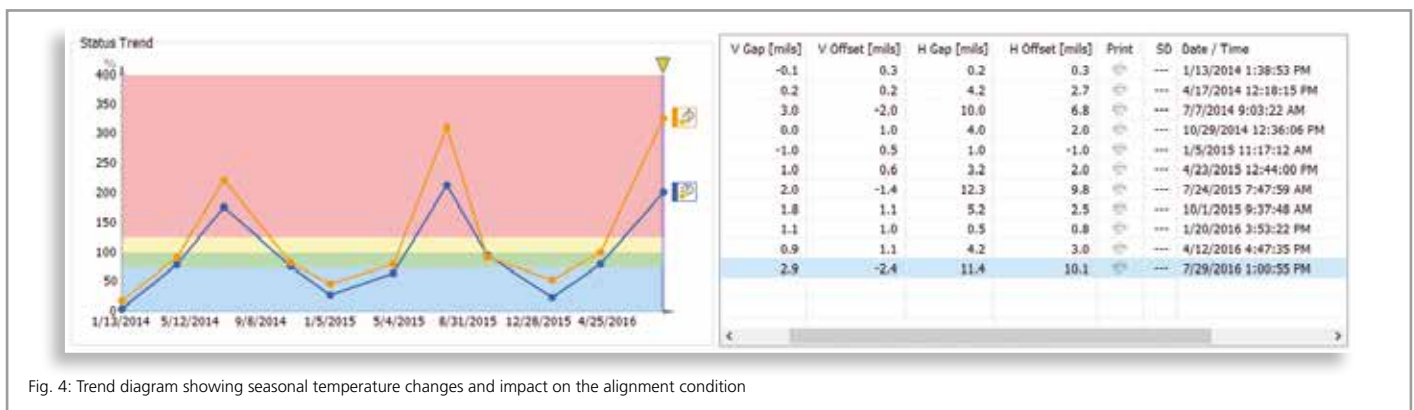

Fig. 4: Trend diagram showing seasonal temperature changes and impact on the alignment condition

Monitoring Machine Health

Knowing the condition of your machines can help avoid or mitigate costly breakdowns and failures. While keeping an eye on vibration levels is one well-established way to monitor the health of rotating machines, capture and analysis of actual alignment data will take your understanding and preparedness to the next level. Instead of merely signaling that a problem is already occurring, periodically checking the state of your alignment may allow you to anticipate or even avert the need for major repairs.

Fully understanding how alignment data changes over time is central to maintaining operational readiness and effective alignment protection. When alignment data are collected and presented graphically in the form of trend lines or charts, such as those produced by PRUFTECHNIK's ALIGNMENT RELIABILITY CENTER 4.0® software, exploring and understanding alignment data trends is easy.

Alignment trend analysis is especially useful in identifying problems due to:

- ▶ **Thermal Expansion** – As machines warm up or cool down, alignment can change significantly. A “hot” alignment can help, but it will not capture all the elements of the changing alignment condition. Over time, machines that are not set-up and adjusted to accommodate thermal expansion and contraction reveal dynamic misalignment problems by their high rates of failure.

- ▶ **Seasonal Effects** – Seasonal changes in temperature can dramatically alter the alignment of rotating equipment. Where pumps or exposed piping are located in an outdoor environment, the equipment is exceedingly vulnerable to significant seasonal effects and temperature extremes that impact alignment.
- ▶ **Alteration in Process Parameters** – Even small changes in the temperature, pressure, or other operating parameters can alter the dynamic forces and alignment of machines.
- ▶ **Sub-Structures or Bases** – Machine bases, skids, or plinths can move causing changes in alignment. Relocation of machines to operating facilities that have different substructures or different degrees of rigidity or flatness can negatively affect alignment.
- ▶ **Uncertainty in Vibration Data** – Sometimes vibration data does not clearly uncover a misalignment condition in time. Vibration analysis is not an exact science and can miss important warning signs of misalignment that alignment trend data could reveal.

Periodic measurement and analysis of alignment data can help identify all of these problems before critical failures occur. At the end of the day, timely information about actual alignment conditions will always be the best weapon in your arsenal to counter the forces that trigger alignment problems. Capture and analysis of alignment data trends will provide that information.

Author:

Greg Lee, Senior Project Manager
PRUFTECHNIK Inc. USA

USA
PRUFTECHNIK Inc.
7821 Bartram Ave.
Philadelphia, PA 19153
Toll free: +1 844 242-6296
Fax: +1 215 893-3902
usa@pruftechnik.com
www.pruftechnik.com

Canada
PRUFTECHNIK
4406, rue Louis-B.-Mayer
Laval, QC H7P 0G1
Tel: +1 514 738-6565
Fax: +1 514 227-5455
info@pruftechnik.ca
www.pruftechnik.ca



PRUFTECHNIK Dieter Busch AG
Oskar-Messter-Str. 19-21
85737 Ismaning
Germany
Tel.: +49 89 99616-0
Fax: +49 89 99616-200
info@pruftechnik.com
www.pruftechnik.com

A member of the PRUFTECHNIK Group